

# Spectrum Sharing and Flexible Spectrum Use

Kimmo Kalliola  
Nokia Research Center

FUTURA Workshop 16.8.2004

# Outline

- Terminology
- Drivers and background
- Current status
- Cognitive radio
- Research activities & technology proposals
  - DARPA XG
  - FCC interference temperature concept
  - Underlay systems (e.g. UWB)
  - Spectrum sharing based on load measurement
  - Semi-dynamic spectrum sharing (spot-market)
  - Common coordination channel
- Summary

# Terminology

## **Spectrum sharing:**

Independent radio systems (like military radars, broadcasters, cellular,...) or independent operators/users use the same spectrum in co-operation (regarding time, place, code and/or event)

## **Flexible spectrum use:**

Devices are able to use spectrum in a flexible manner by adapting their operation to the current situation by e.g. sensing the environment or based on pre-defined regulatory policies that can vary in time, place, code and/or event

# Drivers and background

- More frequency bands will be needed for new high-bit-rate wireless services & devices
- Spectrum sharing and flexible spectrum use can facilitate the successful implementation of future systems especially for local and personal area wireless systems
  - Spectrum sharing rules and etiquettes are necessary for ensuring good user experience
  - Future devices need to have the means for flexible spectrum use
- UWB and 4G systems are typical examples of future high-bit-rate systems that are expected to operate in common bands, since there is not enough (or any) “new” spectrum available



# Current Status

- Advances in technology are creating the potential for radio systems to use spectrum more intensively and efficiently
- There is currently an ongoing dialogue to change spectrum access paradigm from transmitter-based frequency management to more flexible spectrum access methods
- So far the main advocates of flexible spectrum usage have been new companies trying to enter the market especially in the U.S.
- FCC is actively seeking comments and information to form basis for the new spectrum access paradigm:
  - NOI & NPRM on Interference Temperature concept released November 2003 (comments due by April 2004)
  - NPRM on Cognitive radio released December 2003 (comments due by May 2004)
- Comments received from the industry related to interference temperature were mostly pessimistic. It is not clear how FCC will proceed with the matter
- On long term, the most disruptive spectrum sharing scheme is the Cognitive Radio

# Cognitive Radio

- Cognitive radio technology is expected to improve spectrum access through:
  - increased spectrum efficiency of licensed spectrum users
  - secondary markets by allowing licensees to lease their spectrum access e.g. by machine-controlled negotiation between systems
  - automated frequency coordination between licensees
  - opportunistic spectrum use by unlicensed devices while protecting incumbents from harmful interference

# Cognitive Radio

- The radio functionality for advanced flexible spectrum use is demanding, as it requires a considerable amount of intelligence from the transmitting device:

- sensing over wide frequency band
- identifying both other users of that band as well as the available transmission opportunities
- coordinating the actual use of the radio band by communicating with other devices
- conforming to spectrum pooling etiquettes to ensure that no harmful interference is caused to other users

Cognitive<sup>\*)</sup> or smart radios could possess the required capabilities for flexible spectrum use

\*) term coined by Dr. Joseph Mitola III in year 1999

# Cognitive Radio

- A cognitive radio is a software radio equipped with sensors and software that allow it to perceive the operating environment and learn from experience

Internal model of hardware and software structure, knowledge of radio basics

Cognition cycle – learn about networks, locations, user preferences

Cellular standards and spectrum pooling etiquettes can be downloaded on the fly

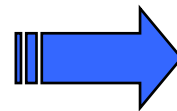
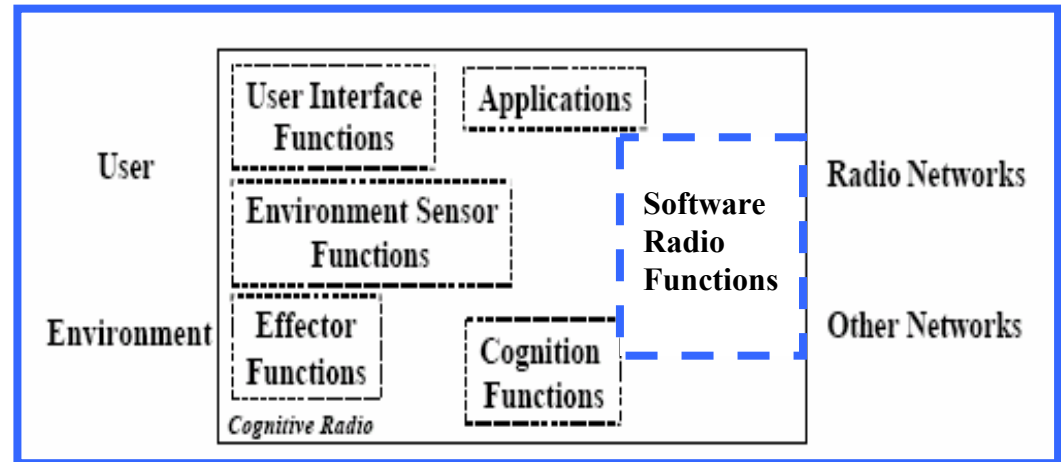

Optimizing the use of radio resources by adjusting transmission parameters >>  
Flexible spectrum use!

# DARPA XG

## Description:

- DARPA XG = Defense Advanced Research Agency NeXt Generation Communications Program
- Duration: 2001-2006
- Key objective:
  - To produce a set of advanced technologies for dynamic spectrum access, including
    - Spectrum measurement techniques
    - Policy based controls
    - XG behaviors resulting into implementation
- Accomplishments so far:
  - First version of frequency sensor completed
  - Three RFC's published for comments: The XG Vision, The Architectural Framework, and Policy Language Framework

## Status and future outlook:

- Program originally initiated for military applications, but it is clear that commercial vendors are required to get wide acceptance for the technology and boost R&D
- The concept will be in spectrum discussions related to WRC07 and 4G, but concrete impacts to regulations not known

# The FCC Interference Temperature Concept

Figure source: FCC Spectrum Policy Task Force (SPTF)

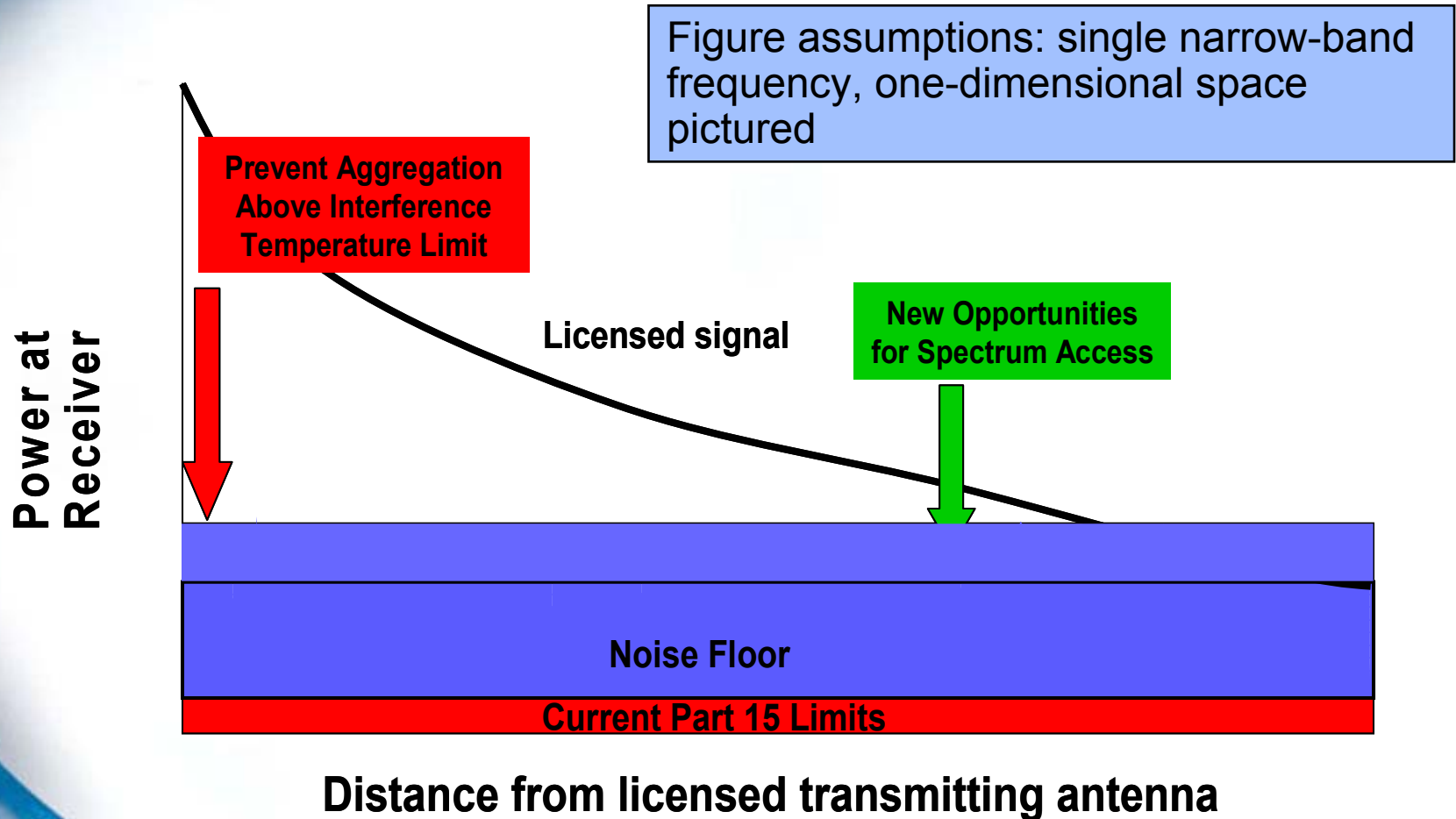

# The FCC Interference Temperature Concept

## Objectives:

- Method for secondary users to access licensed band independent of technology
- More efficient usage of spectrum since more devices can use the same band
- Enabler of short-range UWB type of communications; UWB: high data rate, transmission mask should protect existing system operation
- Fast spectrum access to new systems

## Drawbacks:

- Interference monitoring difficult to implement without the licensed system signal contribution - limits usability in underlay systems
- Practical problems in implementation of interference monitoring (hidden node problem, bandwidth vs. averaging time, receiver noise figure)
- Determining interference temperature limits is very system dependent
- There are cases, when max. interference increase cannot be guaranteed
- The increase in the background interference will affect existing systems

# The FCC Interference Temperature Concept

## Status and future outlook

- FCC is driving the concept forward, but there is no published time schedule
- Majority of the comments received from relevant industries were challenging the basic concept
- Part of the industry, those who are planning interference temperature type systems, are likely to agree and develop their systems accordingly
- Likely to be applied in some bands (e.g. UWB) in the near future (years 2006-2008)
- May not be feasible in cellular bands because of the negative impact due to decreased capacity and smaller cell sizes
- Not useful as such for e.g. 4G as the communications distance is too short (meters at max.)
- Most likely, underlay principle will not be used - rather utilization of un-used gaps in the licensed spectrum

# Underlay Systems (UWB)

- UWB: standardization IEEE 802.15.3a, technology selection ongoing process but there are no globally agreed rules nor spectrum masks for UWB
- Research still required in co-location and interference to victim terminals

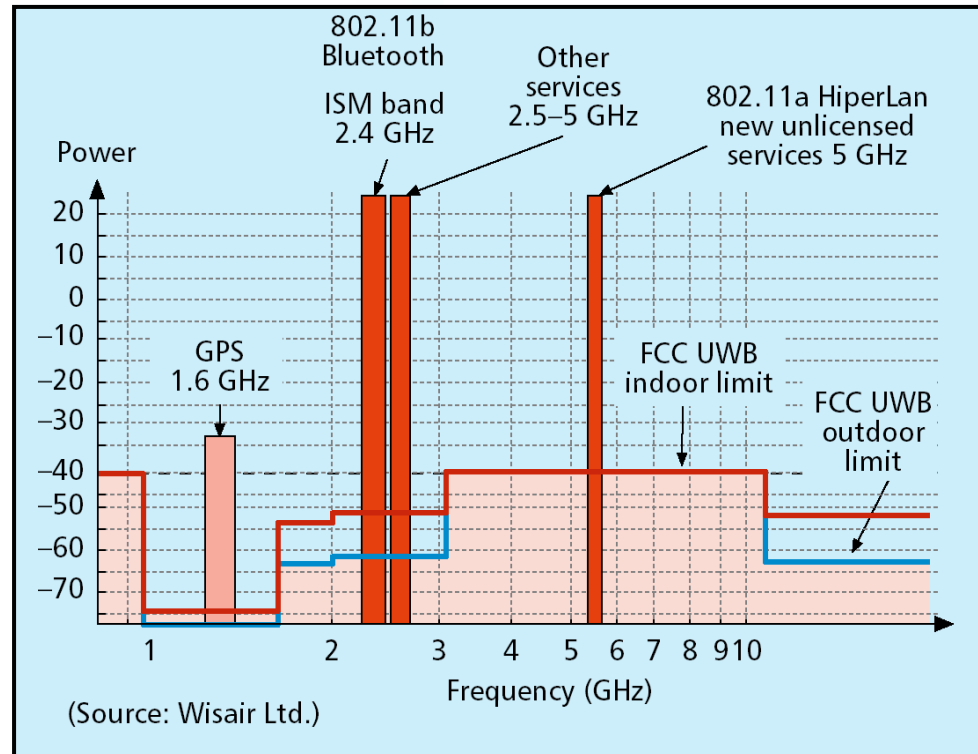

# FSU based on load measurements and prediction

## Concept description:

- Contiguous blocks of spectrum are allocated to participating systems based on load measurements and prediction. Both temporal (e.g. one hour resolution) and regional allocation of spectrum is possible. DSA gains could typically be 20-30%.

## User perspective:

- Suitable for wide-area cellular and broadcast technologies.
- Fits well with “operator centric” business environment: operators could coordinate the spectrum usage between themselves (optimizes the amount of traffic that operators can support with their existing spectrum)
- Monetary issues are not considered, i.e. how DSA, dynamic spectrum allocation, would be done between competitors.

## Possible impacts on the industry as a whole:

- The total spectrum usage may become more efficient allowing higher total capacity and larger market.
- System and terminal complexity would increase

# Common Coordination Channel (CCC)

## Concept Description:

- National / global band(s) for exclusive use by a physical CCC (or piggybacking a logical CCC on existing physical channels)
- CCC could be used either directly between radio devices in a local area or between a radio device and a central coordinator
- CCC would have globally agreed transmission format / signaling protocols
- Each radio device would access the CCC before transmitting and possibly tune the transmission frequency/timing accordingly

# Semi-dynamic spectrum use (“Spot Market”)

## Concept description:

- Access/usage rights to a certain amount of spectrum (at certain location and time) could be bought or booked from a dealer or operator by a user/terminal or by operator
- The dealer could be a government (office) or independent organisation. The operator could sell his extra spectrum. The spectrum could be dedicated or “pooled”

## User perspective:

- Access to spectrum might become easier/faster, but there would usually be a price to pay. However, in competitive environment the cost could be optimized.
- It may be questioned whether a user wants to buy access to spectrum but actually the services. Another difficulty is that he does not know beforehand the amount of data or access time. Clear billing mechanism would be needed.
- The operators are a different case, they need certain amount of spectrum allowing a certain capacity, varying over the time in a predictable manner. Spot market may offer a possibility to sell extra capacity and to buy the required spectrum, but perhaps not with the required certainty.

## Possible impacts:

- Total spectrum usage can be more efficient, higher capacity and larger market
- The spectrum costs may stay on reasonable level if proper competition prevails
- System and terminal complexity would increase

# Semi-dynamic spectrum use: Spot Market

- SOME OPTIONS WHAT IT COULD BE ALL ABOUT

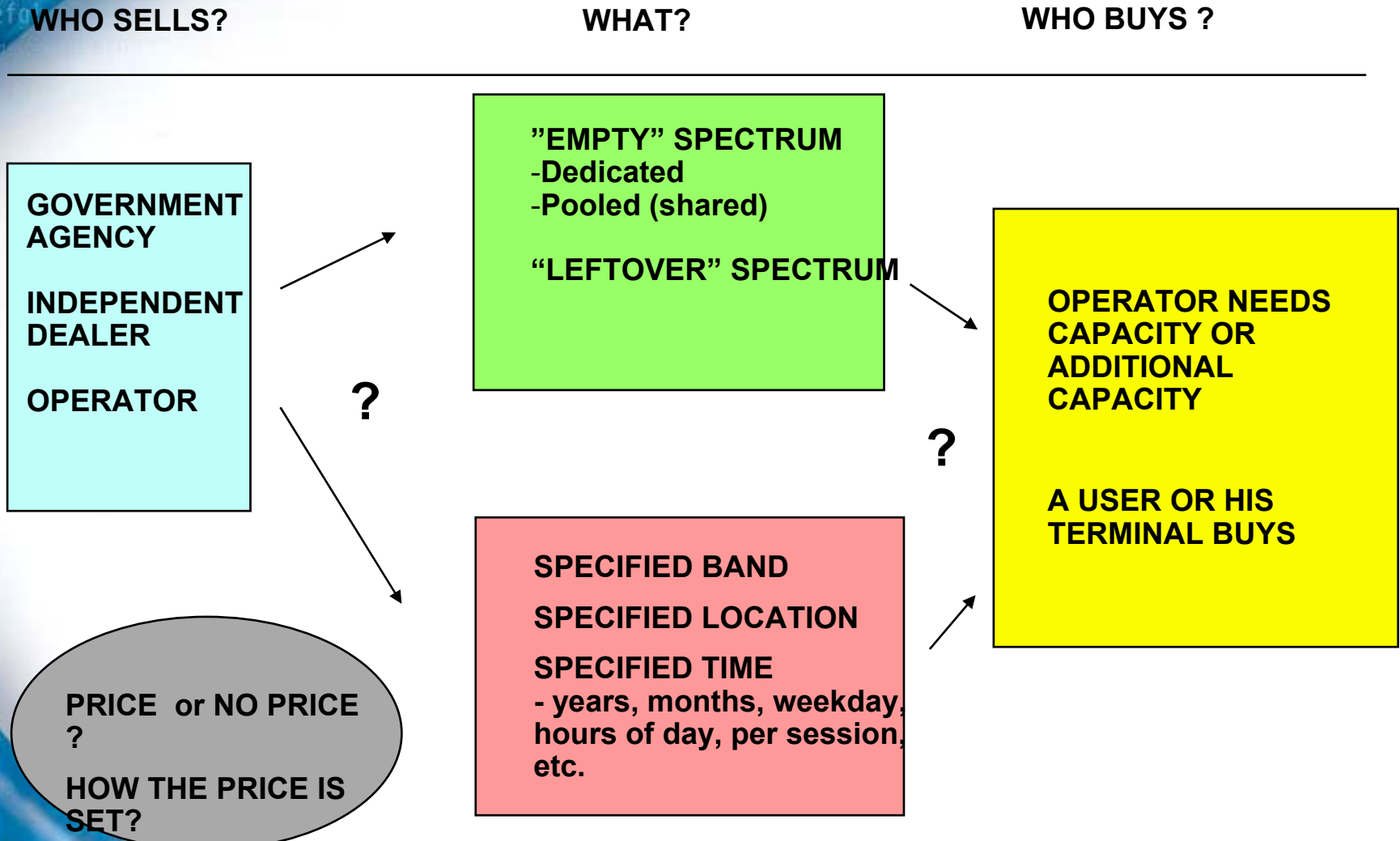

# Summary

- Spectrum sharing between different radio systems is expected to increase
- On long term, the most disruptive sharing scheme could be Cognitive Radio (=ability of the radio device do sense and use available spectrum)
  - Will almost certainly be adopted on a global scale, but only in the next decade due to technology development and standardization / regulation lead times
  - Will have a major impact especially on terminal implementation
- On shorter term, FCC Interference Temperature Concept may be applied in some bands in U.S.
  - More room for underlay - UWB type – transmitters by extending regulation to receiver performance, i.e. requirement to handle interference
  - It is possible that also the cellular bands will have to accept this concept in this decade -> adverse and significant effect on performance of cellular networks
- UWB is already happening, but there are no globally agreed rules nor spectrum masks for UWB, and UWB may suffer from implementation complexity and cost

Thank You!