

Multimedia Processing for applications over future networks

Tsuyoshi HANAMURA, PhD

Visiting Associate Professor, GITS of Waseda Univ.
COO, Media Glue Corporation (MGC)

Principles for R&D and Technology Deployment

- ◆ **Media Glue, Corp. (MGC) is a venture company**
- ◆ **MGC are providing products and services based on multimedia technologies and especially on multimedia transcoding, which are results of collaboration with GITS of Waseda Univ.**
 - Research and development of core technologies are done with laboratories in universities.
 - Application product and service are developed in the form of core library and middleware products.
 - Plan to deploy for world wide market.

R&D and Business Development

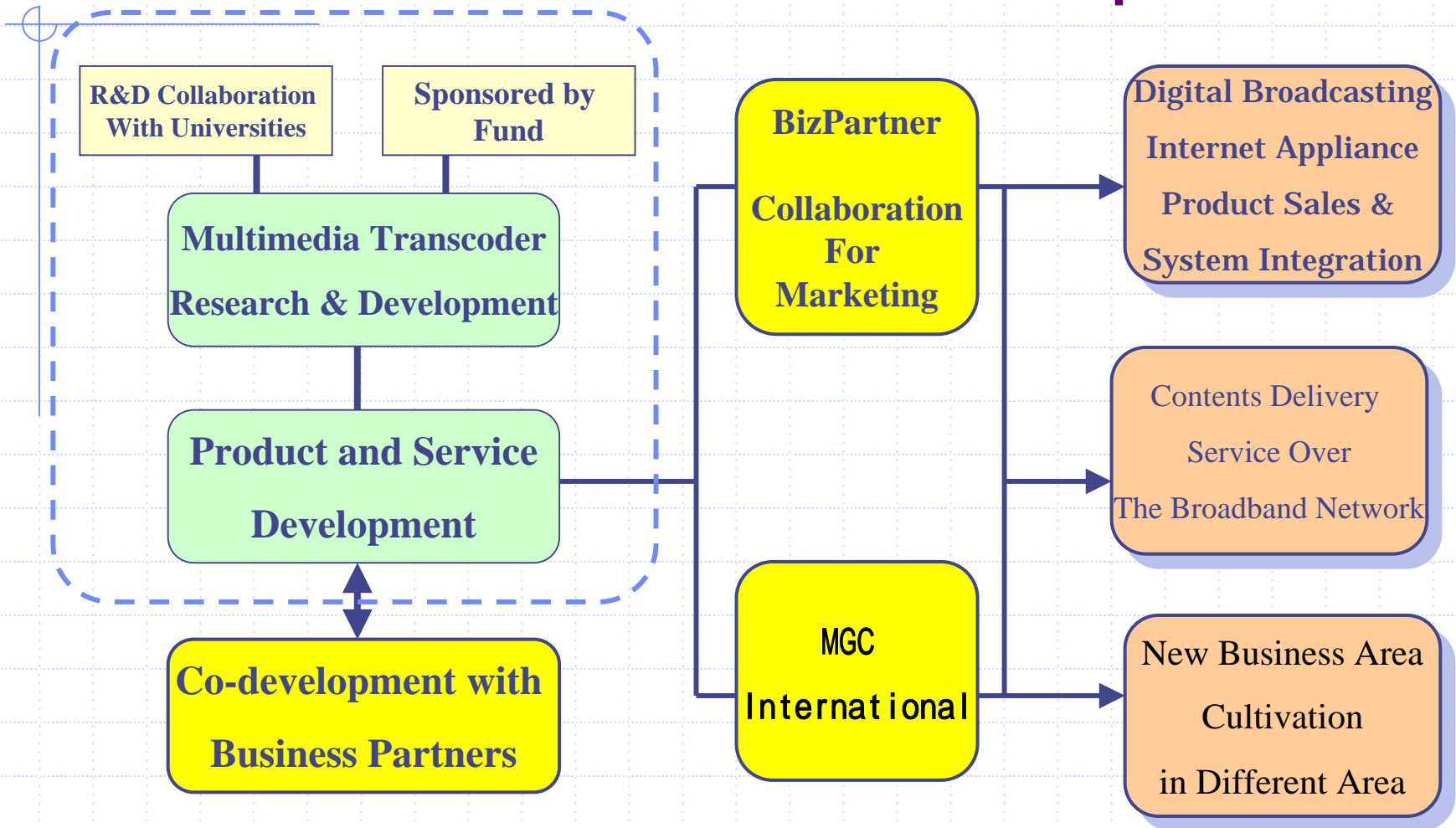

Purpose of the technical presentation

- ◆ To provide technical input from the viewpoint of **APPLICATION** layer
- ◆ To brief requirement of Multimedia processing on delivery of rich content (Audio/Video)
- ◆ To describe a few ways to achieve bitrate scalability feature for multimedia content

QoS for Multimedia transmission

Multimedia:
Audio/Video delivery over network

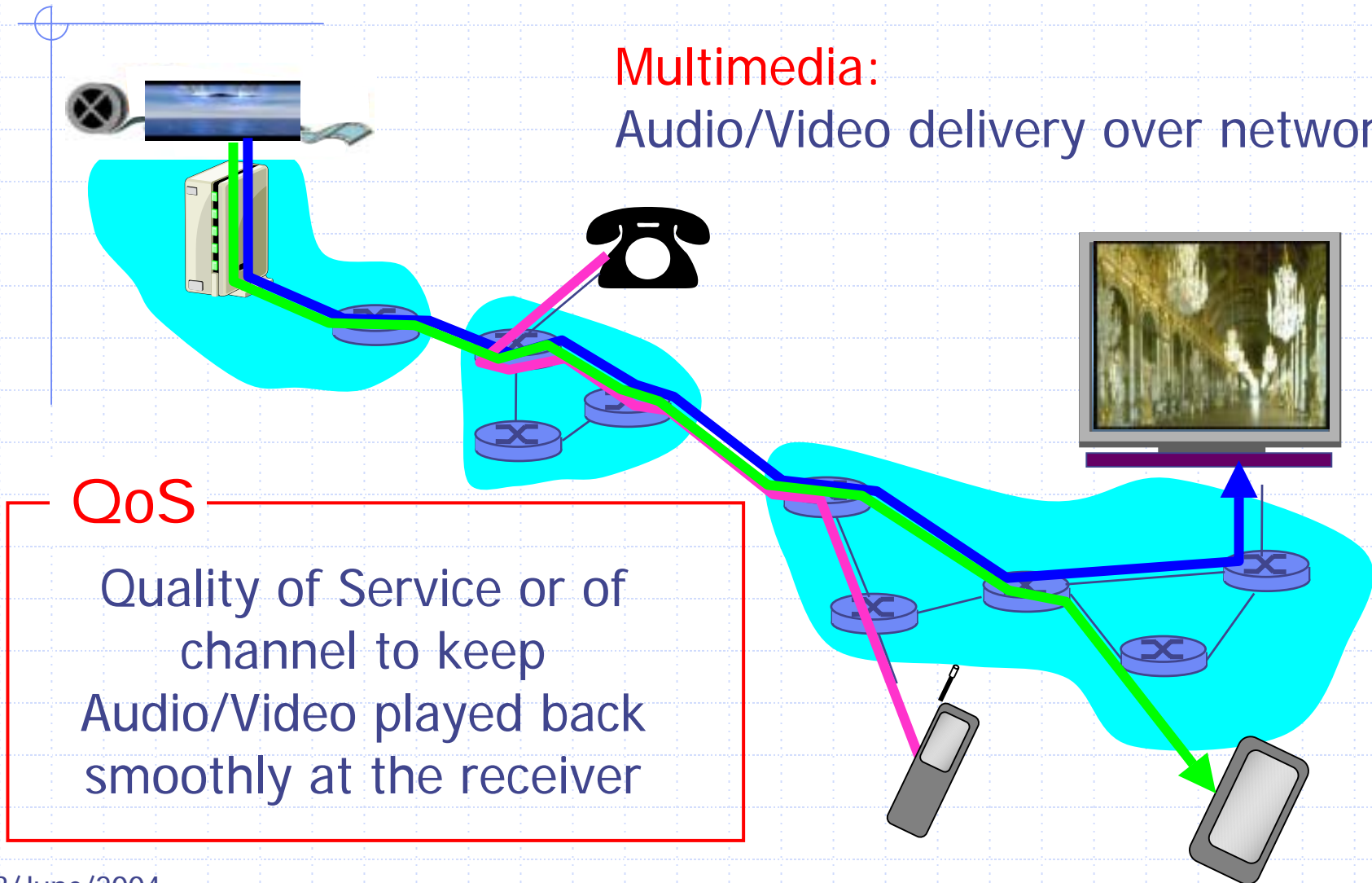

QoS

Quality of Service or of
channel to keep
Audio/Video played back
smoothly at the receiver

Requirements for Audio/Video Content delivery

- ◆ Continuous playback of A/V at receiving end
 - Constant bitrate for end-to-end transmission over QoS guaranteed channel
 - But guaranteed QoS is found impossible for heterogeneous networks
 - Audio/Video content scaling is another way to avoid the problem caused by non-QoS guaranteed channel

Major issues on A/V delivery

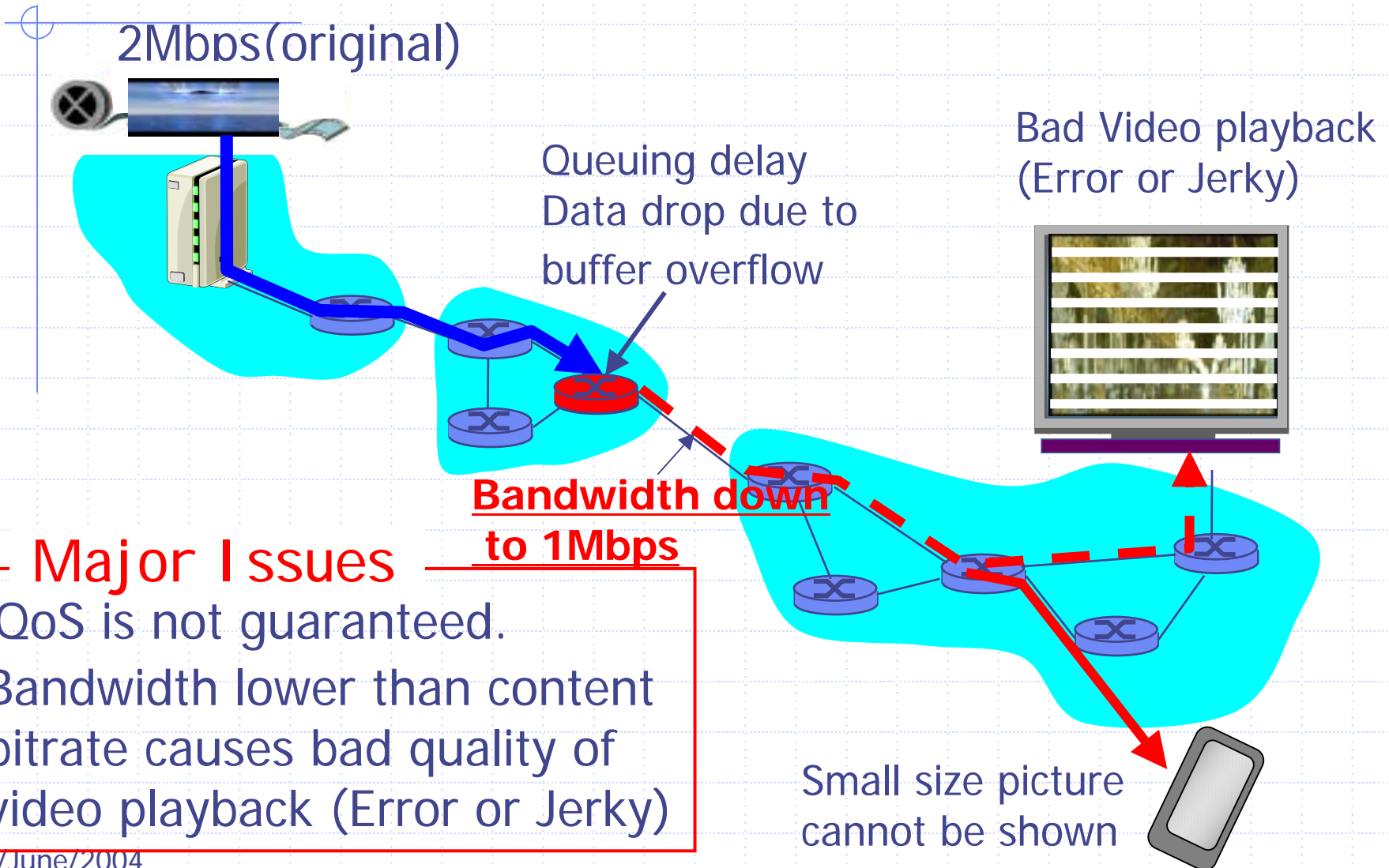

Major Issues

QoS is not guaranteed.
Bandwidth lower than content
bitrate causes bad quality of
video playback (Error or Jerky)

Transcoding : Techniques for Continuous playback of Audio/Video

- ◆ Transcoding is required to alter content bitrate adaptive to change of channel bandwidth
 - Transcoding: Variable Bitrate of Audio/Video, Picture size change.
- ◆ Encoding A/V stream in variable bitrate adaptive to the available channel bandwidth
 - Longer latency to feed back the available bandwidth
- ◆ Transcoding at Network node
 - Bitrate reduction inside node (router, switch, etc.)
 - Multi-layered data generated at sender + channel selection at node

Transcoding at a Node

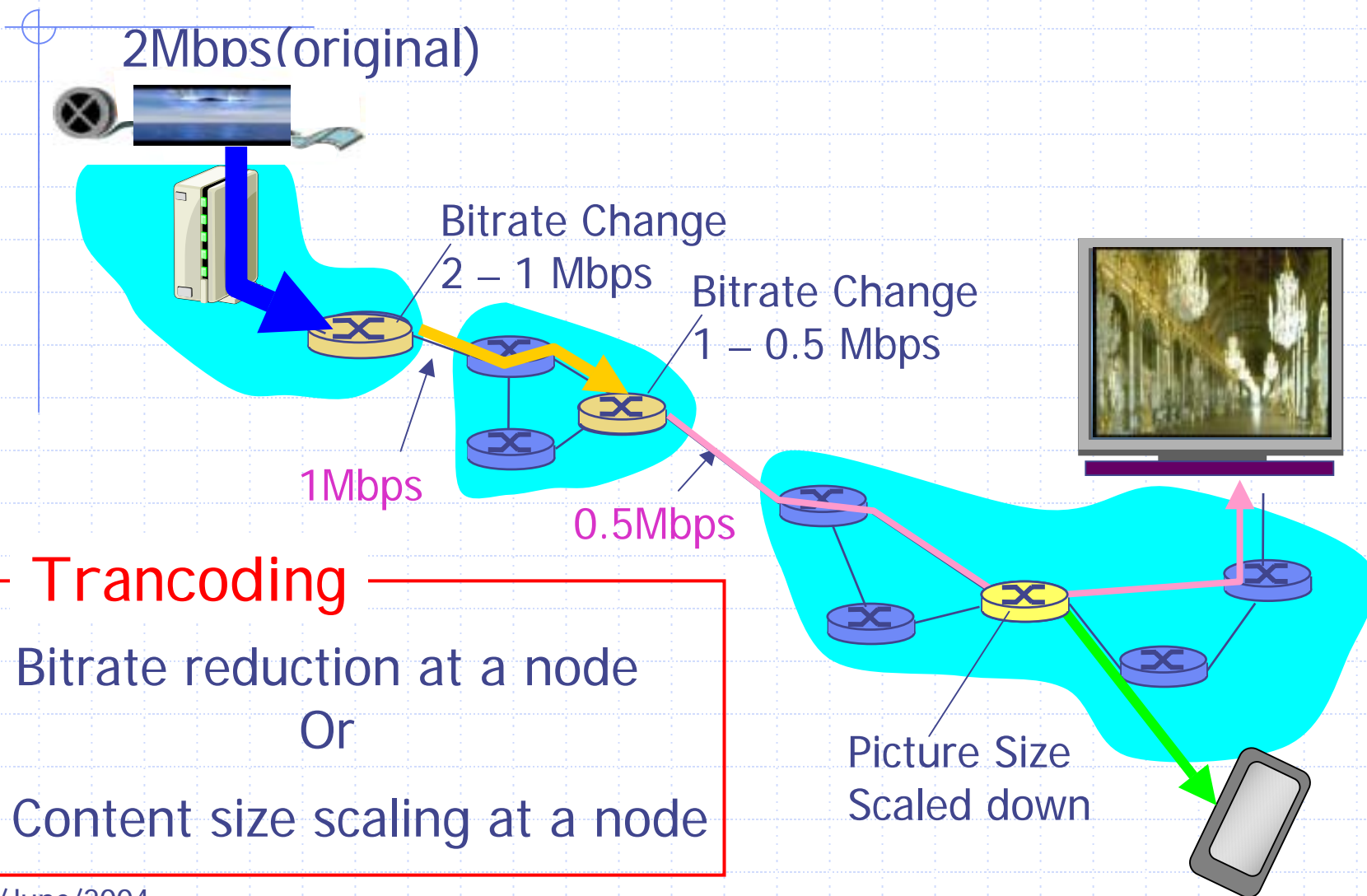

Multi-channel transmission for a stream

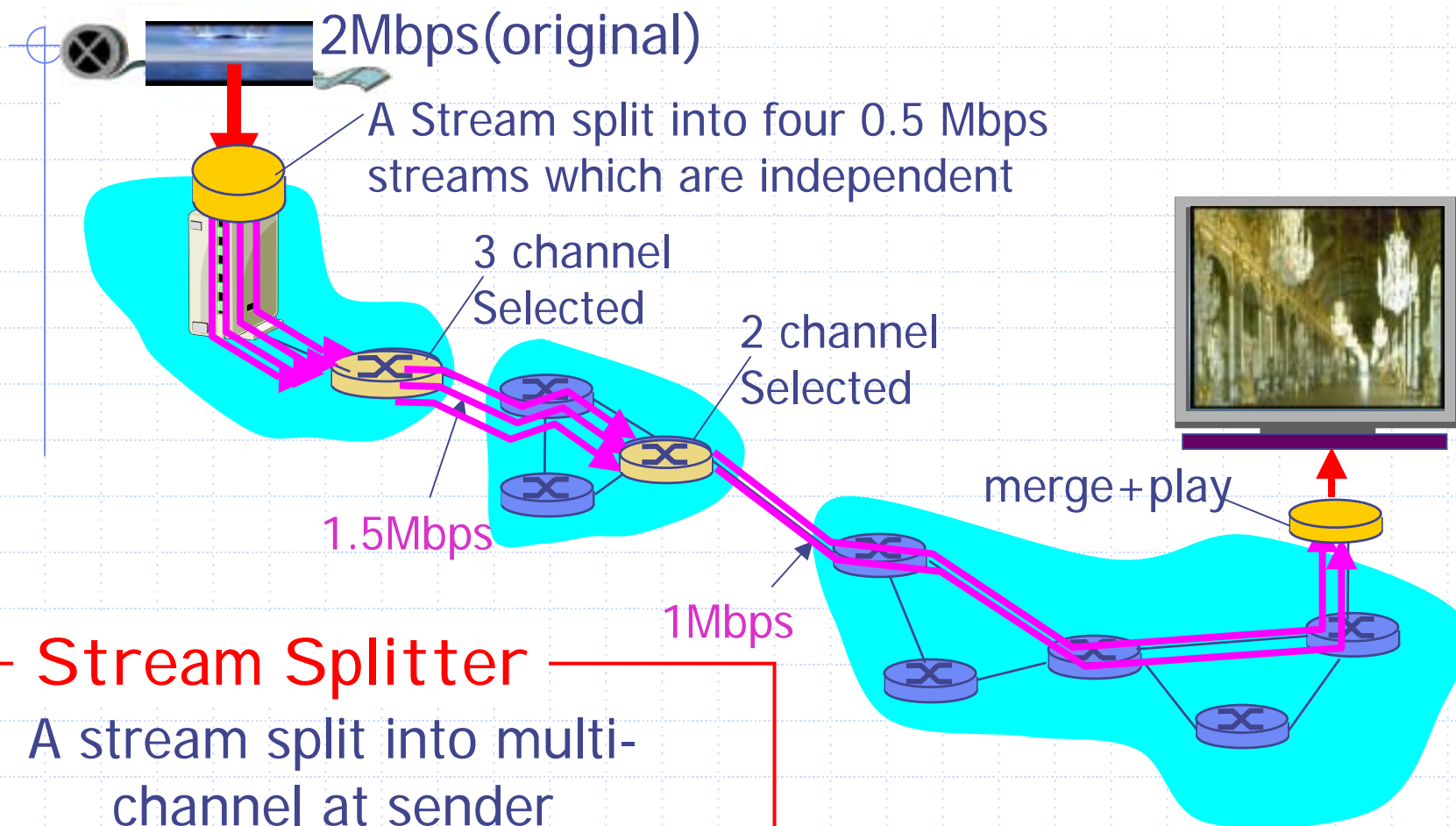

Stream Splitter

A stream split into multi-channel at sender

Channel selection at a node

Types of Transcoder

◆ Rate Reduction Transcoder

- Reduces bitrate of high volume A/V contents
- Dynamic control of output stream bitrate

◆ Separate & merge Transcoder

- Separate a stream into two or more chunks of
- Flexible channel management

◆ Converts MPEG2 to MPEG4 format

- HD to SD, SD to Smaller size, HD to mobile

Bitrate Reduction MPEG-Transcoder

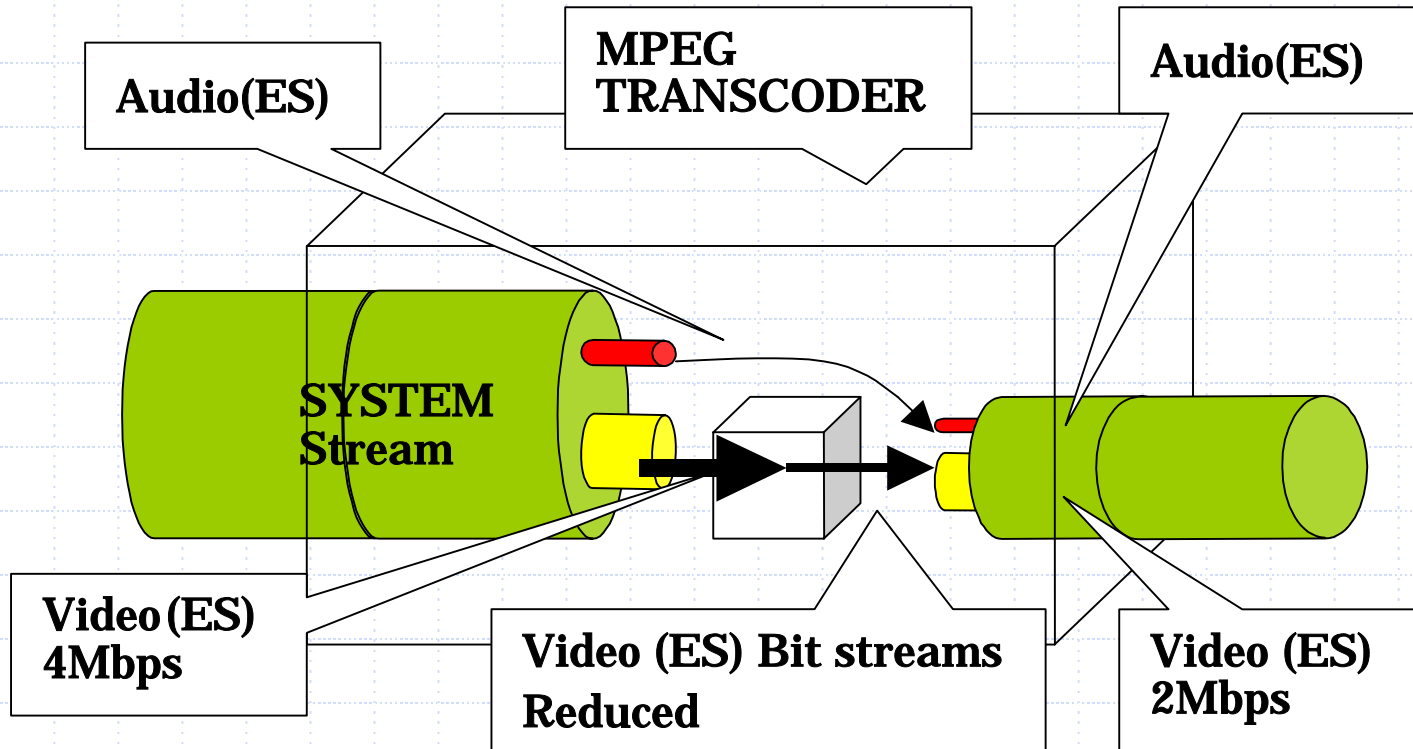

◆ Transcoder for MPEG A/V Content

- ◆ Reduces bitrate of high volume A/V contents to give lower bitrate stream (B-stream)

Separator & Merger of stream for multi-channel output

- ◆ A channel is independent of other channels
- ◆ Channel can be randomly selected at a node based on the output statistics

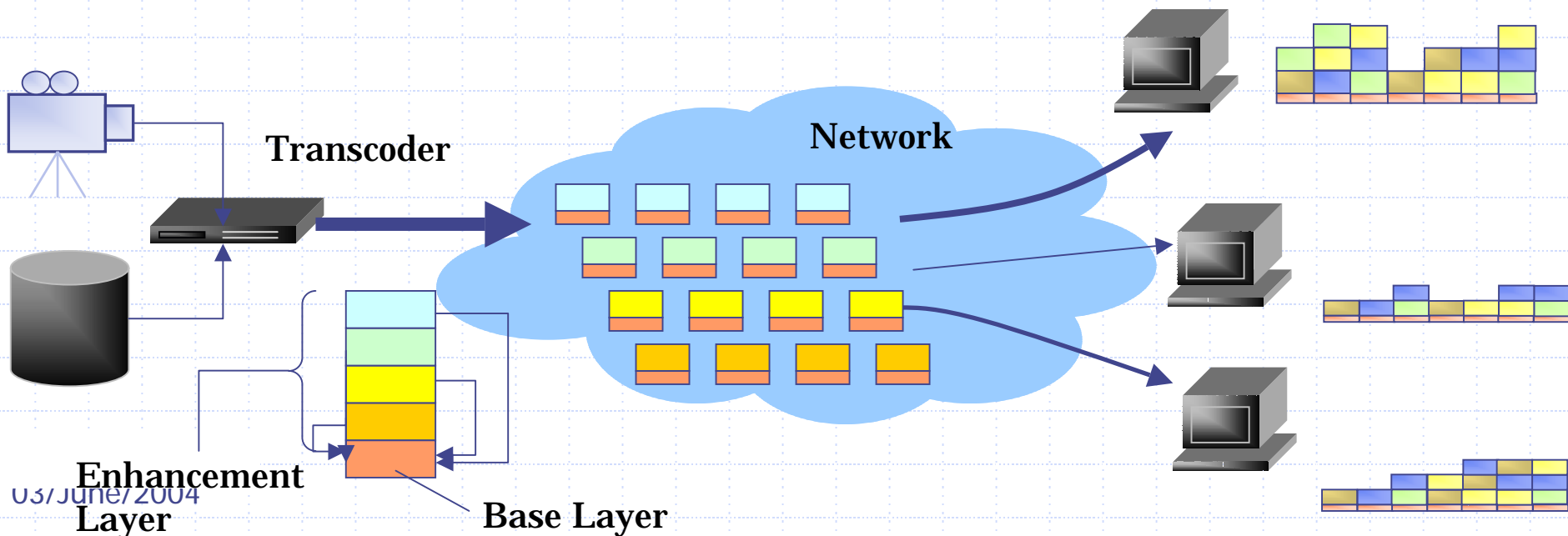

Summary

- ◆ A/V content delivery requirements examined
- ◆ QoS guarantee is not taking place
- ◆ Transcoding is more important
- ◆ Types of transcoder described
 - Bitrate reduction
 - Multi-channel output separator
- ◆ Network should support tracking and prediction of the channel bandwidth availability.
- ◆ Further information: hana@mediagluue.co.jp